



City of Richmond

October 11, 2011
File

Business and Financial Services Department
Finance Division
Telephone: 604-276-4218
Fax: 604-276-4162

Attention: To All Proponents

Dear Madame/Sir:

Re: 4599Q Supply and Delivery of Street Banners - Addendum # 1

This Addendum includes items of clarification, forms part of the Contract Documents and shall be read, interpreted and coordinated with all other parts. Please review and consider the following information in the preparation of your Quotations:

See attached Drawing HHC223 Sheets 1 to 5.

Questions:

Q1) We produce 100 % recycled polyester banners but not nylon. Will you be awarding this contract to one supplier who produces both types of banners ?

A1) The City encourages both Nylon and Polyester banner suppliers to submit a response and sample. The City may or may not award the contract to only one supplier.

Q2) Can you give us an estimate of how many designs per material (ie. x number of designs for RC Poly; for nylon)?

A2) There will be a maximum of four images for the Nylon banners and a maximum of eight images for the RC poly banners.

Q3) Would you consider recycled polyester banners than are less than 100 % recycled ?

A3) The City will not accept less than 100% recycled polyester.

Please acknowledge receipt of this Addendum by submitting a signed copy with your response.

Signature

Print Name & Title

Date

Yours truly,

Daianna Panni
Buyer 1

DP:dp

pc: Dee Bowley, Acting Manager, Parks Programs
Paul Brar, Coordinator, Parks Programs
Serena Lusk, Manger, Parks Programs

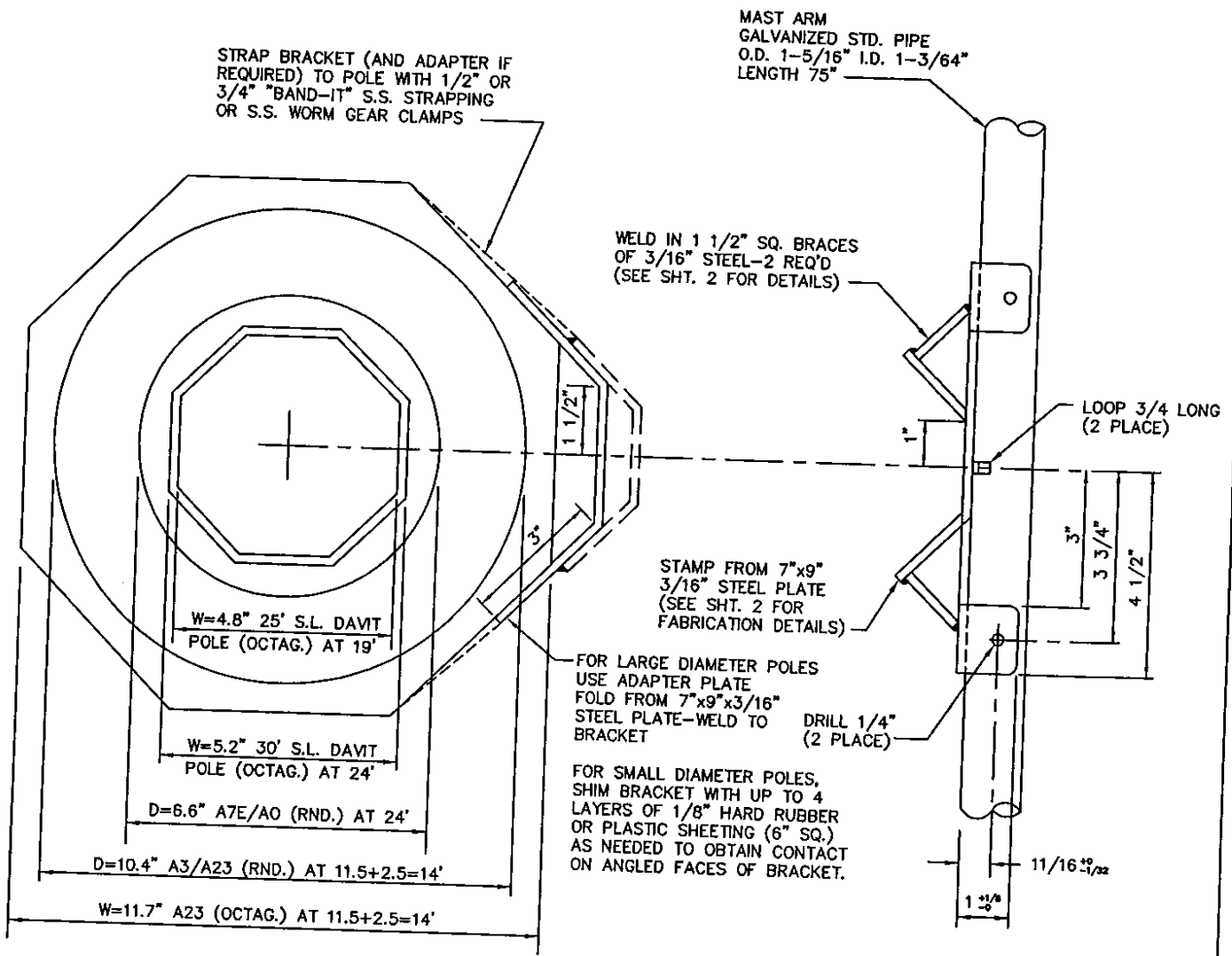

CITY OF RICHMOND

STREET BANNER

UNIVERSAL STREET DECORATION BRACKET

DR. No.
HHC223

SHEET No.
1 of 5

DES.	ENG.
DR. c.y.	DATE OCT. 93
CHK.	SCALE 1/4"=1"

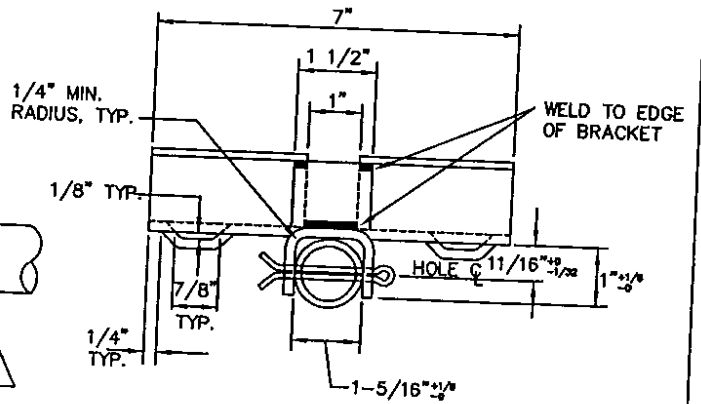
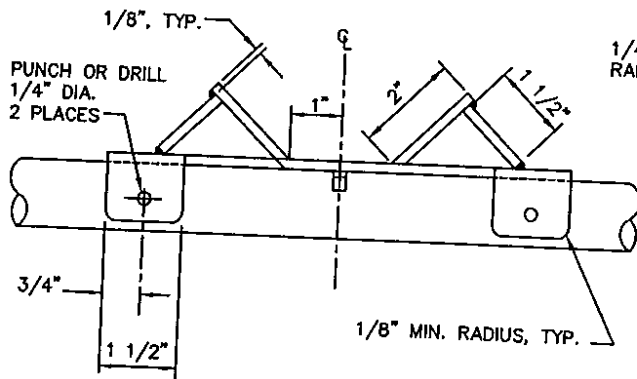

STAMP BRACKET FROM
7"x9"x3/16" STEEL PLATE
GALVANIZED

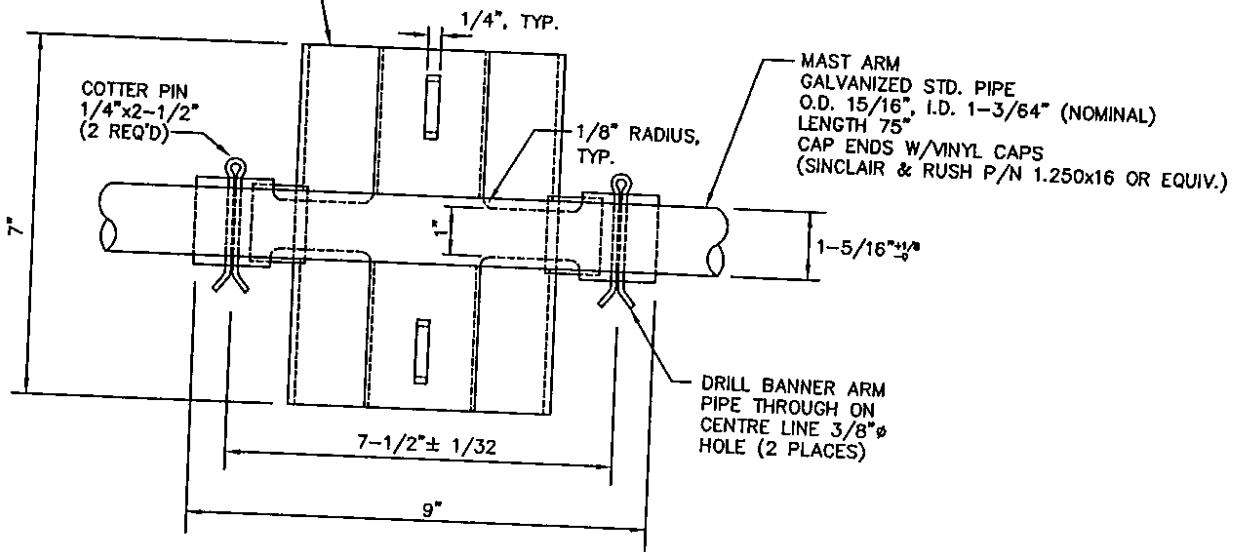

NOTE:

MAST ARM MUST BE INTERCHANGEABLE WITH ANY BRACKET - THEREFORE, HOLE LOCATION TOLERANCES MUST BE OBSERVED.

CITY OF RICHMOND

DES.	ENG.
DR. c.y.	DATE NOV. 93
CHK.	SCALE 1/4"=1"

STREET BANNER
UNIVERSAL STREET DECORATION BRACKET

DR. No. HHC223
SHEET No. 2 of 5

1/4" DIA. (TYP.) 4 PLACES
SEE DWG. HHC223 SHT. 2
FOR HOLE LOCATION AFTER
ALL FORMING OPERATIONS
ARE COMPLETED

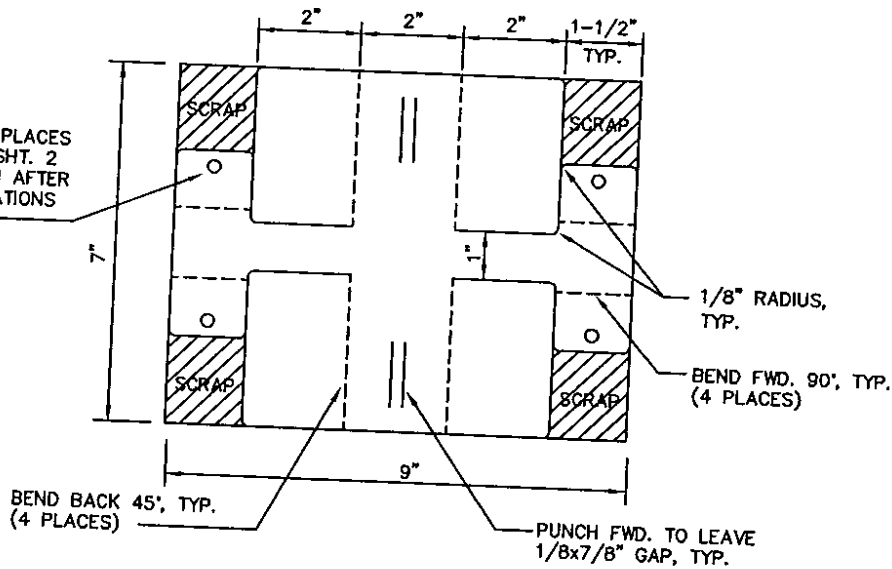

STREET DECORATION BRACKET PATTERN
3/16" STEEL PLATE

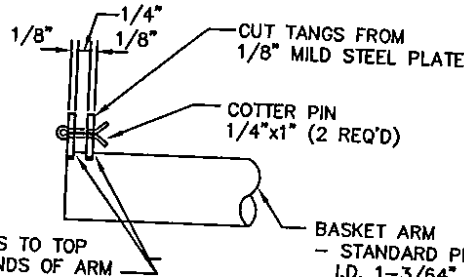
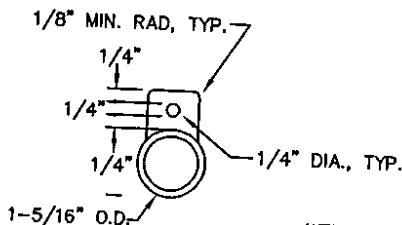

- BASKET ARM
- STANDARD PIPE - O.D. 1-5/16", I.D. 1-3/64", LENGTH 48" DRILL TWO 3/8" DIA. HOLES VERTICALLY THROUGH PIPE C/L 3-3/4" EITHER SIDE OF MIDDLE OF ARM TO TAKE BRACKET MOUNTING PINS. (SEE SHT. 2 FOR DETAILS)
- PRIME & PAINT C OF V GREEN ENAMEL (OR CUSTOM COLOUR AS ORDERED)

**FLOWER BASKET ARMS FOR USE WITH
UNIVERSAL STREET DECORATION BRACKET**

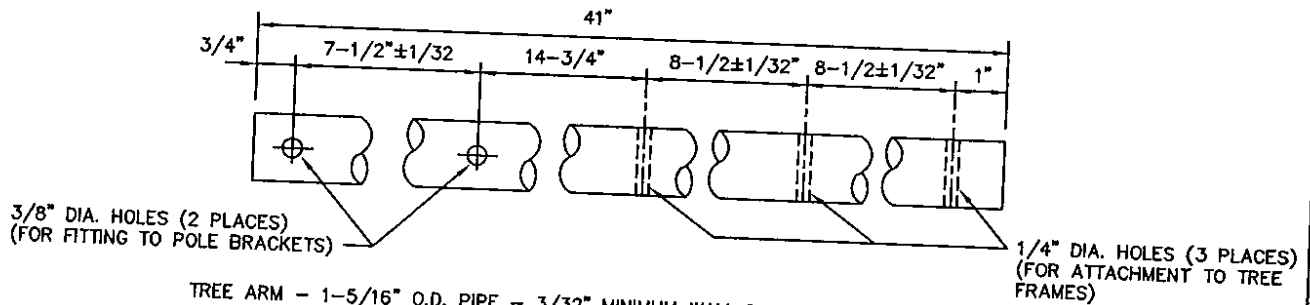

- TREE ARM - 1-5/16" O.D. PIPE - 3/32" MINIMUM WALL THICKNESS 6061-T6 ALUMINUM (PREFERRED) OR STEEL (OPTIONAL)
- LENGTH 41" DRILL TWO 3/8" DIA. HOLES HORIZONTALLY AND THREE 1/4" DIA. HOLES VERTICALLY THROUGH PIPE/TUBE AS SHOW
- LEAVE UNFINISHED UNLESS PAINTING SPECIFIED ON WORK ORDER

**SINGLE CHRISTMAS TREE ARMS FOR USE WITH
UNIVERSAL STREET DECORATION BRACKET**

CITY OF RICHMOND

DES.	ENG.	STREET BANNER UNIVERSAL STREET DECORATION BRACKET	DR. No. HHC223
DR. c.y.	DATE NOV. 93		SHEET No. 3 of 5
CHK.	SCALE 1/4"=1"		

INSTALL EA. 4 SPLIT PINS
(1/4"x2-1/2") WITH EYES ON
BANNER SIDE OF BANNER ARMS

527 MX TY RAP (4 REQ'D)
-DO NOT OVER TIGHTEN
-CUT OFF EXCESS

TROLLEY/O.S.L. POLE

BRACKET (2 REQ'D)

1. Mount banner brackets to pole at 78" or 90" centres (as specified), on the side of the pole away from approaching traffic. (In cases where other hardware on the pole interferes with this mounting position, the brackets may be mounted on the side of the pole facing approaching traffic.)
2. Mount banner brackets using two 3/4" "Band-it" straps, passing each strap through the loops provided on the bracket (some brackets may have two sets of loops - use the loops closest to the top and bottom of the bracket). In exposed, high wind areas such as bridges or water front areas, add two more 3/4" "Band-it" straps; one each just above and just below the banner arm attachment tangs.
3. On large octagonal poles, the angled faces of the bracket do not sufficiently bridge one face of the pole to allow at least 1/2 inch of contact between the angled bracket faces and the angled pole faces. On these poles and on round or fluted poles whose diameter at the bracket mounting location exceeds 10 inches, use modified brackets with welded-on, oversize backing plates.
4. Install a banner arm into the claws at either side of the upper bracket and pin in place with two 1/4" x 2-1/2" split pins with the eyes of the split pin DOWN.

NOTE: Each pin must have BOTH legs bent away from each other a MINIMUM of 45° (so that the included angle between the bent part of the pin legs is a MINIMUM of 90°).

5. Ensure that there is a vinyl end cap on each end of the banner arm, then slide the upper sleeve of each banner over each arm. using one 527 MX Ty Rap cable tie for each banner, tie the banners to the banner arm split pin by passing the tie through the grommet in the banner and through the eye of the split pin. Do not over tighten the Ty rap or it will place undue strain on the grommet. Rotate Ty Rap so that its head rests against the eye of the split pin and cut off the excess Ty Rap tail.
6. Ensure that there is a vinyl end cap on each end of the lower banner arm and slip the arm into the lower banner arm and slip the arm into the lower sleeves of the banners. Install the arm into the claws at either side of the lower bracket and pin in place with two 1/4" x 2-1/2" split pins with the eyes of the split pins UP. Bend both legs of the split pins per the NOTE in paragraph 4 above and tie the banners in place per the instructions in paragraph 5 above.
7. If for any reason, the banner arm split pins are removed, the pins are to be discarded. They SHALL NOT be re-used. Similarly, no attempt is to be made to salvage or re-use the Ty Rap ties.
8. When banners are removed for the season, the arms are to be removed for storage and the brackets are to be inspected for security and condition. Damaged brackets shall be replaced and loose brackets shall be re-straped at this time. Bent arms shall be straightened prior to placing them in storage. Severely damaged arms shall be discarded after removing their end caps for return to stock. Loose or damaged brackets and bent or damaged arms are to be reported by street and pole number to the Electrical and Communications Design Engineer, local 7366.

VINYL END CAP (4 REQ'D)
SINCLAIR + RUSH P/N
1.250x16 (OR EQUIV.)

3/4" BAND-IT

3/4" BAND-IT
(OPTIONAL-SEE TEXT)

BANNER ARM
(2 REQ'D)

45° MIN.
TYP.

NOTE:

EXCEPT IN CASES WHERE EXISTING
POLE HARDWARE INTERFERES
-MOUNT BANNER HARDWARE ON
SIDE OF POLE AWAY FROM
APPROACHING TRAFFIC

BANNER HARDWARE

CITY OF RICHMOND

DES.	ENG.
DR. c.y.	DATE NOV. 93
CHK.	SCALE 1/4"=1"

STREET BANNER
UNIVERSAL STREET DECORATION BRACKET

DR. No.
HHC223

SHEET No.
4 of 5

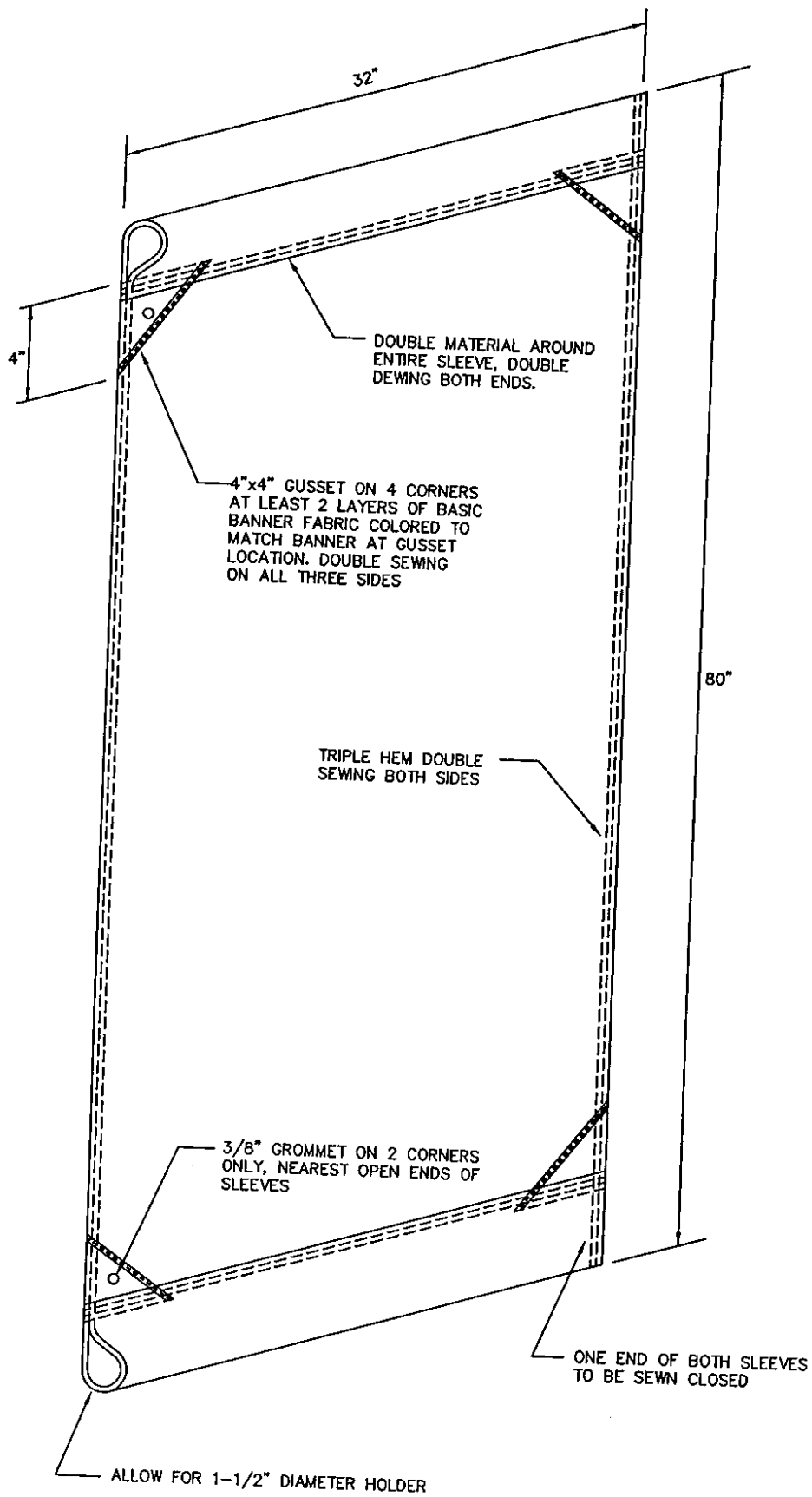

CITY OF RICHMOND

STREET BANNER

SKETCH OF TYPICAL BANNER

DES.	ENG.
DR. c.y.	DATE NOV. 93
CHK.	SCALE 1/4"=1"

DR. No. HHC223
SHEET No. 5 of 5