

PLAN VIEW

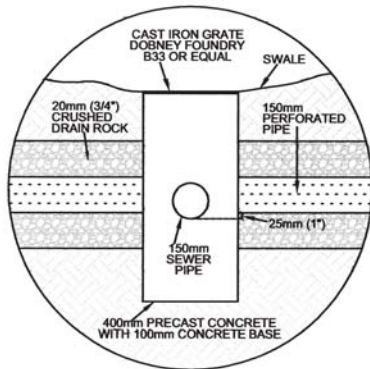

DETAIL A
TYPICAL INSPECTION CHAMBER

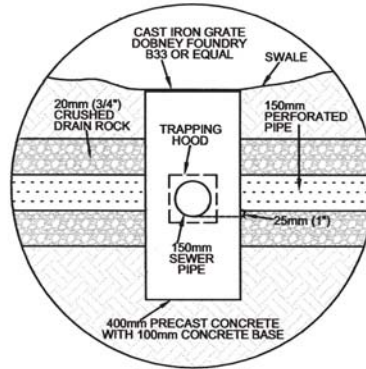

DETAIL B
TYPICAL PERIMETER DRAIN
INSPECTION CHAMBER
CONNECTING TO STORM.

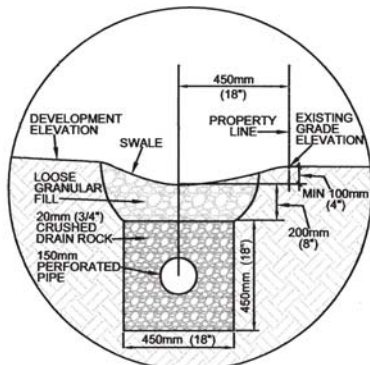

SECTION A-A
DETAIL OF TYPICAL
PROPERTY LINE DRAINS

NOTES:

1. MATERIAL & GRADES TO COMPLY WITH RICHMOND GUIDE TO COMMERCIAL INSTALLATION.
2. ALTERNATE INSPECTION CHAMBERS MUST CONNECT TO STORM SYSTEM.
3. THIS SYSTEM REQUIRED WHERE DEVELOPMENT PROPERTY IS RAISED ABOVE OR SLOPES TOWARDS AN ADJOINING PROPERTY.



City of Richmond

Typical Perimeter Drain Diagram for Commercial & Multiple Family Dwelling Sites

Dr. No.: P-105

Sheet No.: 1 of 1

Scale: NTS

Date: 2003/03/14