

# CITY OF RICHMOND INVITATION TO TENDER

## Contract T.3733

### Contract: Watermain Replacement - No. 3 Road from Cook Road to Granville Avenue

The City of Richmond invites tenders for construction work at the above-mentioned locations. Work under the Contract generally comprises:

- Supply and installation of 495 lineal metres 300mm dia. and 5 lineal metres of 200mm dia watermain, fully joint restrained;
- Supply and installation of 9 fire hydrants and 13 service connections of various sizes;
- Provisional items such as replacing curb and gutter, boulevard or sidewalk.

The *Contract Documents* are available on or after August 10, 2009 during normal business hours at Front of House of the Richmond City Hall at:

6911 No. 3 Road, Richmond, BC, V6Y 2C1

on payment of a **non-refundable** amount of \$50.00 including GST payable to:

#### City of Richmond

Vendors are responsible for arranging their own Couriers for picking up copies of the documents. All Couriers must come with the required cheque/cash and be prepared to complete the Tender Document form with Company Name, Contact information, Telephone Number, Fax and E-mail address.

The *Contract Documents* are available for viewing at:

Front of House, Richmond City Hall, 6911 No. 3 Road, Richmond and Vancouver Regional Construction Association, 3636 East 4th Avenue, Vancouver.

#### Tenders are scheduled to close at:

**Tender Closing Time:** 3:00 PM local time

**Tender Closing Date:** Thursday, August 25, 2009 and will be opened publicly immediately thereafter in Richmond City Hall

**Tender Submission Address:** Manager – Purchasing & Stores  
Front of House, Richmond City Hall  
6911 No. 3 Road, Richmond, BC, V6Y 2C1

A tender consists of a submission delivered on time complete with the required Bid Bond, Undertaking of Surety and Undertaking of Liability Insurance.

The lowest or any tender will not necessarily be accepted.

Manager – Purchasing & Stores



## City of Richmond

6911 No.3 Road, Richmond, BC V6Y 2C1

Telephone (604) 276-4000

www.city.richmond.bc.ca

## City of Richmond

August 21, 2009

File: 10-6340-30-3733/Vol 01

**Engineering**

Telephone: (604) 276-4289

Fax: (604) 276-4197

TO THOSE WHO HAVE RECEIVED COPIES OF T.3733

Dear Sir/Madam:

**Re: Contract T.3733  
Addendum No. 1  
Watermain Replacement - No.3 Road from Cook Road to Granville Avenue**

This addendum forms part of the Contract Documents and shall be read, interpreted and coordinated with all other parts. The costs of all work contained herein shall be included in the Contract Price. The following revisions supersede the information contained in the original Contract Document to the extent referenced and shall become part thereof.

Tenderers shall acknowledge receipt of this addendum by:

**1. Inserting its number and date where provided for on the Form of Tender.**

**2. Closing Date**

Please note that the Tender Closing Date has been changed:

Was: Tuesday, August 25, 2009 at 3:00pm

Is Now: **Thursday, August 27, 2009 at 3:00pm**

**3. Design Drawings Changes and Clarifications**

**3.1. Design Drawings Changes**

3.1.1. Replace the typical trench detail shown on the drawing Wc-955 sheet. 4 of 7 with the typical trench detail shown on the attached drawing Wc-955 Watermain Construction No. 3 Road (East Side) from Granville Avenue to Westminster Hwy Addendum No.1.



3.1.2. Add the following note on the drawing Wc-955 sheet 1 of 7:

25. Watermain pipe joints to be wrapped with the denso tape within 3.0m horizontal or 0.5m vertical separation with storm and sanitary sewer. Watermain pipe crossing a storm or sanitary sewer to cross midway between joints.

3.1.3. Add water service connections on the east side of No.3 Road as follows:

- 25 mm connection at 6560- No. 3 Road
- 25 mm connection at 6600- No. 3 Road
- Second 25 mm connection at 6860- No. 3 Road
- Third 25 mm connection at 6860- No. 3 Road
- 25 mm connection at 6858- No. 3 Road
- 25 mm connection at 6852- No. 3 Road
- 50 mm connection at 6838- No. 3 Road

3.1.4 Delete the water service connections on the east side of No.3 Road as follows:

- 25 mm connection at 6400- No. 3 Road

3.1.5 Delete the water service connections on the west side of No.3 Road as follows:

- 150mm connection at 6911- No. 3 Road

3.1.6 Change the size of the water service connections on the east side of No.3 Road as follows:

- proposed 25 mm connection to HSBC at 6800 to be replaced with the 50 mm connection
- proposed 25 mm connection to IHOP at 6780 to be replaced with the 40 mm connection

#### **4. Contract Documents Changes and Clarifications**

##### **4.1 Tender Submission Documents Form of Tender Schedule of Quantities and Prices Changes**

Replace Page B-9 of Form of Tender Schedule of Quantities and Prices with the attached Page B-9 rev.1.

##### **4.2. Supplementary Specifications (SSP)**

###### **4.2.1. Contract Time SSP3**

Insert the following sentence after the first sentence:

*The Contractor will be required to construct (in advance of the centre median works) all service connections and hydrant leads across No. 3 Road. The **Milestone Date** for the installation of the service connections and hydrants leads across No. 3 Road from Cook Road to Granville Avenue is **September 15, 2009**.*

The remainder of the paragraph stay the same.

#### 4.2.2 Traffic Control SSP 23.2 Specific Requirements

Replace the wording under the first bullet as follows:

*"The Contractor shall be responsible for coordinating and scheduling the watermain works including traffic management with Imperial Paving Ltd. who are responsible for the No. 3 Road Restoration works which includes the construction of a new centre median from Cook Road to Granville Avenue. If required by Imperial Paving Ltd., the Contractor will have to reschedule the watermain works to accommodate the No. 3 Road Restoration works. The Contractor's will not be entitled to any compensation, in damages or otherwise, associated with any watermain construction scheduling around the No. 3 Road Restoration works.*

*The Contractor must allow a minimum of one traffic lane in each direction without any median cross-over for the mainline water installation. For coordination and scheduling enquiries regarding the No. 3 Road Restoration works, the Contractor must contact: Wayne Baldwin, Project Manager, Imperial Paving Ltd. at 604 -880-4789 (cell). For any City related enquiries regarding the No. 3 Road Restoration work, the Contractor can contact: Rob Fylling, Site Inspector, Major Projects, City of Richmond at 604-516-9448 (cell).*

*The working hours for No. 3 Road are from 7 am to 5 pm."*

#### 4.3. City of Richmond Supplementary Specifications Changes

##### 4.3.1. Section 02666 Waterworks

##### 4.3.1.1 Add New Item 2.5.2 (ss):

*"All service connections should be complete with tracer wire and stainless steel sleeves at joints in accordance with manufacturer's recommendations."*

### **5. Questions and Answers**

**5.1 Q.** Is the Contractor responsible for full depth (6") asphalt restoration only and the final mill & overlay to be done by others?

**A.** The Contractor is responsible for the full depth initial asphalt restoration as per typical trench detail attached to this Addendum No.1. The final mill & overlay to be done by others.

- 5.2 Q.** Are the Provisional Items (i.e concrete restoration) machine work or handwork? Also do these pay items include concrete restoration at Hydrants & Services?
- A.** The quantities and locations for the provisional items B-1 and B-2 are not know at this time and depend on proximity of the proposed watermain alignment to the existing curb & gutter and sidewalk. The curb and gutter can be either installed by either handwork or machine laid.
- The provisional items B-1 and B-2 do not include concrete restoration at hydrants and services. The pay items A-2 and A-3 include surface restoration for hydrants and services.
- 5.3 Q.** Is the cost to remove and replace Traffic/Pedestrian Loops Detectors borne by the City?
- A.** The cost to remove is borne by the Contractor but the cost to replace is borne by the City.
- 5.4 Q.** Who's responsible for Temporary Line Painting (i.e Crosswalk,etc.)?
- A.** The contractor is responsible for Temporary Line Painting.
- 5.5 Q.** The existing sidewalk is made up of Brick Pavers (accent) & 4" concrete, are we supposed to replace the Brick Pavers with Brick Pavers or can it be straight 4" concrete as well?
- A.** For hydrants and service connection installations the contractor is responsible to replace the existing brick pavers with the brick pavers and to reinstate the remaining sidewalk with the concrete. At the locations where provisional item B-2 would apply the disturbed sidewalk areas to be reinstated with concrete and the disturbed boulevard areas can be reinstated with either concrete or with paverstone. The contractor will be allowed to re-use the existing paverstones if they are in acceptable condition.
- 5.6 Q.** How many signs will we be required to install (SSP23)?
- A.** Advisory signage needs to be in place at the following locations:
- No 3 Rd & Granville Ave - 3 signs
  - Granville Ave westbound prior to Buswell St - 1 sign
  - Buswell St & Anderson Rd - 2 signs
  - Buswell St & Park Rd - 3 signs
  - Buswell St & Cook Rd - 3 signs
- 5.7 Q.** Please clarify the number of valves that need to be removed (note 15, drawing Wc-955 sheet 1 of 7).
- A.** Delete Note 15 as the City is responsible for removing the old valve boxes and associated work.

**5.8 Q.** There should be provisional units to cover extra bends and joint restraints required by note 23, sheet 1.

**A.** The Contractor shall make sufficient allowances for bends, fittings and joint restraints to cross the identified service connections under pay item A-1. In situations where it would be determined that a scope change applies in accordance with MMCD GC7 or GC8, the cost of such work would be determined in accordance with MMCD GC9 or GC10 if applicable.

**5.9 Q.** According to your typical section for service connections on sheet 7, there are 7 existing services between the new main and the east property line (4.5m). This will be impossible to install by trenchless methods safely. This should be open cut. Furthermore, if they are open cut, a schedule of restorations should be made available for each service. Presumably, full panels would need to be restored and a block out for the meter box left.

**A.** The drawings do not specify the method of installation for the water services between the new main and the east property line. The City prefers these service connections to be installed by open cut methodology but will accept trenchless installation methods. The contractor shall include the required surface restorations for service connections in Pay item A-3.

**5.10 Q.** If we are responsible for legal survey restoration (SSP12), we need the current legal survey information in order to quantify this work.

**A.** The City has adopted Metro Vancouver's High Precision Network (HPN) benchmarking systems. There are no HPN monuments on No.3 Road between Granville Avenue and Cook Road. The contractor is required to return any disturbed old monuments to the City's Survey Department at no cost to the City. As per SSP12, the Contractor is responsible to replace all disturbed legal information (iron pins, stakes) and shall retain a BC Land Surveyor approved by the Contract Administrator. However, the cost for this Work shall be as a negotiated change order to the Contract.

**5.11 Q.** Since there is no way to quantify the number of services that may need to be altered by the City (SSP6), the costing to "sufficiently expose the utility to be altered to allow the alteration work to take place" should be handled on a force account basis.

**A.** The Contractor is responsible to expose the existing underground utilities crossing the proposed watermain prior to the watermain installation and report any discrepancies to the Contract Administrator. The Contractor shall in no way restrict the activities of the City or applicable utility crew when alterations are being carried out.

According to Measurement of and Payment for Work Item 1 General:  
"Any work called for in the Specifications or shown or implied on the drawings or necessary for the completion of the work called for in the Specifications, which is not specifically listed as a separate item in the Schedule, will be deemed incidental to the General purpose of the Contract and no separate payment will be made on account of any

such work, but the cost of any such work will be included in the tendered unit prices or lump sum prices for the various items of work appearing in the Schedule.”

In situations where it would be determined that a scope change applies in accordance with MMCD GC7 or GC8, the cost of such work would be determined in accordance with MMCD GC9 or GC10 if applicable.

**5.12 Q.** We ask to bid the current Watermain Replacement Project (No. 3 Road from Cook Road – Granville Avenue) as an alternate with the process of pre-chlorinated pipe bursting.

**A.** According to the Instructions to Tenderers Part 1 Item 5.1 any alternative tender must be in addition to, and not in substitution for, a tender which conforms to the requirements of the Contract Documents.

Yours truly,

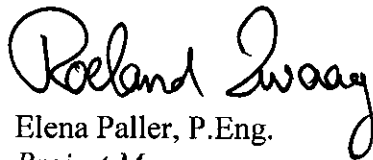

*per* Elena Paller, P.Eng.

*Project Manager*

EP:ep

Attachment: Typical Trench Detail Drawing Wc-955  
Form of Tender Schedule of Quantities and Prices Page B-9 rev.1.

<b>T.3733 –Watermain Replacement - No. 3 Road from Cook Road to Granville Avenue</b>					
<b>SCHEDULE OF QUANTITIES AND PRICES</b>					
<b>ITEM NO.</b>	<b>DESCRIPTION</b>	<b>UNIT</b>	<b>EST. QTYS.</b>	<b>UNIT PRICE (\$)</b>	<b>TOTAL AMT. (\$)</b>
A.	<b>WATERMAIN ITEMS</b>				
A-1	Supply and install PVC Class 150 (DR18) AWWA C900 watermain (fully joint restraint, including fittings). a) 200mm b) 300mm	Lin. m Lin. m	5 495		
A-2	Supply and install complete fire hydrant (including fittings, valves and accessories)	Each	9		
A-3	Supply and install complete service connections as per drawings (including fittings and valves): a) 25mm dia b) 50mm dia c) 40 mm dia	Each Each Each	13 4 1		
A-4	Pressure testing, cleaning, flushing, and disinfecting watermain system.	<b>LUMP SUM</b>			
<b>TOTAL FOR WATERMAIN ITEMS - ITEM A (Carry forward to Tender Summary)</b>					<b>\$</b>



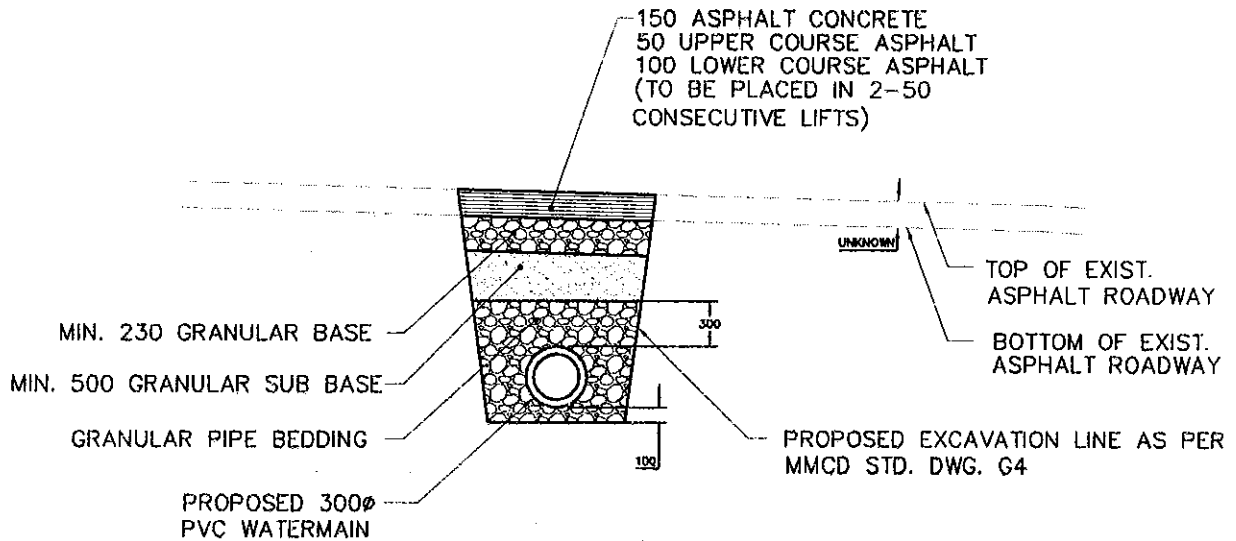

## TYPICAL TRENCH DETAIL

1:50

City of  
Richmond

6911 No. 3 ROAD RICHMOND B.C. V6Y 2C1

**TITLE:**  
**WATERMAIN CONSTRUCTION**  
**No 3 ROAD (EAST SIDE)**  
**FROM GRANVILLE AVE TO WESTMINSTER HWY**  
**ADDENDUM No 1**

DESIGN: JM

DRAWN: JV

CHECKED: JL

ENGINEER: JM

DWC. No. Wc-055

SCALE: NTS

SEC. No.

DATE: 18/09/09

SHT. No.