



**CITY OF RICHMOND
INVITATION TO TENDER**

Contract T.3921

Storm Sewer Construction: Garden City Road: Alderbridge Way to Cambie Road

The City of Richmond invites tenders for construction work at the above-mentioned locations. Work under the Contract generally comprises:

1. Supply and install 710 lineal metres of 1200mm diameter storm sewer and 34 lineal metres of 1350mm diameter storm sewer;
2. Supply and installation of 24 lineal metres of 750 mm diameter storm sewer and 39 lineal meters of 300-375mm diameter storm sewer;
3. Supply and install 8-1800mm diameter storm manholes
4. Road restoration,
5. Landscape restoration in the median.

The *Contract Documents* are available on or after August 5, 2010 during normal business hours at Front of House of the Richmond City Hall at:

6911 No. 3 Road, Richmond, BC, V6Y 2C1

on payment of a non-refundable amount of \$50.00 including HST payable to:

City of Richmond

Contractors are responsible for arranging their own Couriers for picking up copies of the documents. All Couriers must come with the required cheque/cash and be prepared to complete the Tender Document form with Company Name, Contact information, Telephone Number, Fax and E-mail address.

The *Contract Documents* are available for viewing at:

Front of House, Richmond City Hall, 6911 No. 3 Road, Richmond

Tenders are scheduled to close at:

Tender Closing Time: 3:00 PM local time

Tender Closing Date: Thursday, August 26, 2010 and will be opened publicly immediately thereafter in Richmond City Hall

Tender Submission Address: Manager - Purchasing
Front of House, Richmond City Hall
6911 No. 3 Road, Richmond, BC, V6Y 2C1

The lowest or any tender will not necessarily be accepted.

Manager - Purchasing



City of Richmond

August 20, 2010
File: 10-6340-20-P.08302/Vol 01

Engineering
Telephone: 604-276-4289
Fax: 604-276-4197

TO THOSE WHO HAVE RECEIVED COPIES OF T.3921

Dear Sir/Madam:

**Re: Contract T.3921
Addendum No. 1
Storm Sewer Construction Garden City Road: Alderbridge Way to Cambie Road**

This addendum forms part of the Contract Documents and shall be read, interpreted and coordinated with all other parts. The costs of all work contained herein shall be included in the Contract Price. The following revisions supersede the information contained in the original Contract Document to the extent referenced and shall become part thereof.

Tenderers shall acknowledge receipt of this addendum by inserting its number and date where provided for on the Form of Tender.

1) ITT Clause 4.9 - Award

a) *Add the following to the end of Clause 4.9:*

“Tenderers shall allow a period of three (3) weeks from the date of closing of tenders to the Notice of Award.”

2) SECTION F – GEOTECHNICAL REPORTS

a) *Delete the following pages located after Levelton Consultants Limited Groundwater Investigation:*

E-mail from Doug Newton to Carlos Rocha, two (2) pages

3) QUESTIONS RECEIVED FROM CONTRACTORS & SUBSEQUENT ANSWERS

1. Q: What exactly does the City want when you require the contractor to obtain gas permit crossings? What is the contact information? Why would the City not get this information in advance in order to expedite the project?
A: *The design drawings have been forwarded to Terasen for their review. At this point, Terasen has yet to advise on their permit requirements. Any costs associated with Terasen permit fees will be addressed via change order if an answer is not received prior to the tender close.*

2. Q: Can all of the laterals that are 450mm and smaller be concrete or must they be PVC?
A: *Laterals to remain PVC to allow maximum clearance to the Terasen gas main.*
3. Q: Do you want bells and plugs or stubs and caps, as noted on the drawings, for the lateral connections at the proposed manholes?
A: *Either option is acceptable.*
4. Q: Is Amoco 2016 filter cloth to be used on all of the laterals in addition to the mainline on Garden City and Cambie?
A: *Filter cloth is required on the mainline only.*
5. Q: Can MMCD riser manholes be used in lieu of 1800mm barrels?
A: *1800mm barrels are to be used.*
6. Q: Do you have test hole data for the thickness of the existing asphalt?
A: *No asphalt cores were taken. As these are arterial roads, nominal asphalt thickness is expected to be 150mm. Per SSP 19, no extras will be considered for sawcutting of asphalt or concrete thickness up to and including 200mm.*
7. Q: Considering Bid Item B-1 50mm asphalt permanent restoration we assume 150mm pavement patching at 3 layers as incidental cost to storm sewer items, do you confirm?
A: *Section A Storm Sewer pay items to include 150mm pavement patching and lane marking restoration. Item B-1 will cover permanent restoration of asphalt and lane markings to be done after trench settlement occurs.*
8. Q: Density tests cost included in tender price?
A: *All testing costs are to be included in the tender price.*
9. Q: Is there any restriction for working between 8 a.m. to 5 p.m.
A: *There are no restrictions during these hours beyond those noted in the tender documents and City Bylaws.*
10. Q: Is there any restriction for working at intersections (or allowed to work just at weekends)?
A: *Refer to SSP 23. Work at Cambie Road to be done between 2000 and 0600. Work at the minor intersections (Odlin, Alexandra, McKim, Leslie) can be done during normal working hours.*
11. Q: Line painting restoration included in tender price?
A: *Yes, restoration of all line painting is to be included in the tender price. See response to Question 7.*
12. Q: Is Geotechnical Report available to bidders to review?
A: *Geotechnical Exploration Report prepared by Trow was included in Section F of the tender documents following the Limited Groundwater Investigation.*
13. Q: Are there any monuments or legal pins that are likely to be damaged by the Contract?
A: *No monuments or legal pins are expected to be damaged. If one is encountered in the field, the Contractor is to advise the Contract Administrator prior to disturbing the pin or monument.*

14. Q: Has the City considered inserting an escalation clause based upon the current liquid asphalt rate, so the paving companies can provide the best pricing based on today's rate rather than prognosticating the future?

A: *No escalation clause is being considered at this time.*

15. Q: On Garden City Road, it would be beneficial if the Contractor could close one lane completely for the duration of construction as the City recently allowed for the force main on Blundell Road. This would expedite the project and reduce costing for daily trench repair.

A: *Garden City Road southbound can be reduced to one lane for a maximum continuous period of 2 months, however, the Cambie Road/Garden City Road intersection must have all lanes and movements maintained except for when work is active within 50m of the intersection.*

16. Q: Are there any detector loops likely to be damaged by this Contract? If so, who pays for the repair?

A: *Detector loops are present in the eastbound lanes of Cambie Road. The Contractor is to advise the City prior to damaging any detector loops (refer to SSP 23). The City will be responsible for the costs of reinstating any detector loops damaged as a result of unavoidable conflicts with the project design. Repairs for damage to any other loops will be charged back to the Contractor. All work on detector loops will be done by the City.*

17. Q: Is there a maximum trench width that the City will pay for on the overlay?

A: *Initial trench restoration to be included with Section A – Storm Sewer pay items (see response to Question 7).*

For pay Item B1 - Permanent Restoration, both Garden City Road and Cambie Road are classified as arterials (refer to CoR Roadway Restoration Regulation Bylaw 7869 Section 3.2.1) requiring full lanewidth overlay.

Trench width for Garden City Road mainline is to be within the limits of one lane, with the possible exception of the portion south of Alexandra Road which will be reviewed in the field. For Cambie Road mainline, trench width is to be within the limits of two lanes. All other traffic requirements must also be maintained. Permanent Restoration outside of these limits will be the responsibility of the Contractor.

18. Q: How is the traffic to be routed for the construction on Cambie Road? Since the storm will straddle both east bound lanes, do we assume that the north west bound lanes will be used for single lane traffic in each direction?

A: *Due to the volume of traffic at this intersection the work within the intersection must be conducted at night (refer to SSP 23.2). A minimum of one lane in each direction is required when working at this location. Note that the Contractor is responsible for submission of a detailed Traffic Management Plan (refer to SSP 23).*

4) DEADLINE FOR INQUIRIES

- a) *Please be advised that the deadline for inquiries related to the Tender is 5:00 pm, local time on Friday, August 20, 2010. Inquiries received after this time will not be addressed by the City.*

Sincerely,

A handwritten signature in black ink, consisting of a large, stylized 'M' and 'C' intertwined.

FOR:

Milton Chan
Engineering & Public Works



City of Richmond

August 23, 2010
File: 10-6340-20-P.08302/Vol 01

Engineering
Telephone: 604-276-4289
Fax: 604-276-4197

TO THOSE WHO HAVE RECEIVED COPIES OF T.3921

Dear Sir/Madam:

**Re: Contract T.3921
Addendum No. 2
Storm Sewer Construction Garden City Road: Alderbridge Way to Cambie Road**

This addendum forms part of the Contract Documents and shall be read, interpreted and coordinated with all other parts. The costs of all work contained herein shall be included in the Contract Price. The following revisions supersede the information contained in the original Contract Document to the extent referenced and shall become part thereof.

Tenderers shall acknowledge receipt of this addendum by inserting its number and date where provided for on the Form of Tender.

- 1) **Dwg LC-1151 Sheet 1 of 5, rev 9**
 - a) *Delete Project Specific Note 3.*

- 2) **Dwg LC-1151 Sheet 5 of 5 rev 9**
 - a) *Delete and replace with attached Dwg LC-1151 Sheet 5 of 5 rev 10*

- 3) **SSP 7 – Dewatering and Drainage**
 - a) *Last paragraph – Delete “If wellpointing is required...storm sewer system.”*
 - b) *Add new paragraph – “If wellpointing is required, the City will retain an environmental consultant to monitor the groundwater quality. Per City of Richmond Bylaw 8475, discharge to storm sewer must meet the British Columbia Water Quality Guidelines. For this contract, the Contractor is to discharge to the sanitary sewer system and assume no treatment of groundwater for dissolved metals and/or total metals. Should groundwater treatment for dissolved metals and/or total metals for discharge into the sanitary sewer system become required, the costs will be addressed via Change Order to the Contract. Groundwater cannot be discharged to the Leslie Sanitary Pump Station, and 40L/s is allowed to be discharged to the Odlin West Sanitary Pump Station (see Addendum 2 Figure 1). Treatment of trench dewatering for the purposes of sediment control shall be incidental to the Contract, and be included in the relevant pay items.”*

4) QUESTIONS RECEIVED FROM CONTRACTORS & SUBSEQUENT ANSWERS

1. Q: The bedding detail noted on sheet 5 of 5 on Drawing LC-1151 for T.3921 is impossible to build. In order to set the pipe on grade, the bedding is brought to approximate grade and the pipe is set to final grade by either pushing on top of the pipe, or raising the pipe slightly to allow more bedding to be forced underneath. Once the pipe is to grade, the balance of the bedding is added. There is then no way to install geogrid under the cradle of the pipe. At best you can fold the geogrid over the top of the bedding to the sides of the pipe, or completely wrap the pipe and then add the type 1 bedding.
Furthermore, the clear bedding should be placed to springline. There is no way to ensure that the type 1 bedding will complete the cradle below springline in a tight trench. Since clear bedding has a tendency to "flow" to shape and can be knifed easily, it ensures the cradle is complete.
A: *Refer to amended Dwg LC-1151 Sheet 5 of 5 rev 10.*
2. Q: Does the overlay on Cambie need to be done 22:00 to 06:00?
A: *Yes, all work on Cambie is subject to SSP23.2.*
3. Q: Why is there a unit for topsoil and seeding of the boulevards, when the scope of work does not encroach the median area?
A: *This is a provisional sum to be used at the discretion of the City. The contractor is not to disturb the median areas without prior approval from the Contract Administrator.*
4. Q: As per SSP 7, last paragraph, Contractor is responsible for all groundwater treatment cost to discharge the groundwater into the storm sewer system. Is the cost incidental to Section A Storm Sewer item?
A: *See Addendum No 2, Item 3 (above). Should the Contractor choose to discharge to the storm sewer system, all costs of water treatment shall be borne by the Contractor and be included in Section A – Storm Sewer pay items.*
5. Q: Trow Geotechnical Report on page 5 considered heavy groundwater and loose/soft deposits and warned that dewatering can cause settlements beyond dewatering area then recommended sheet piling and also dewatering inside the sheet piling, please clarify if all these costs will be incidental to Section A Storm Sewer item.
A: *Construction methods including choice of shoring system are to be determined by the contractor. All shoring and dewatering costs except treatment for dissolved metals and/or total metals to meet Metro Vancouver requirements for discharge into the sanitary sewer system are to be incidental to the Section A – Storm Sewer items.*

Sincerely,



FOR:

Milton Chan
Engineering & Public Works

[Zoom In](#) [Zoom Out](#) Zoom In / Out to: [Pan](#) [Last View](#) [Max View](#) [Overv. Map](#) [Print](#)
[Identify](#) [Property Info](#) [Select](#) [Query](#) [Buffer](#) [Clear](#) [Measure](#) [Set Units](#) [Download](#)

Cursor will: **Pan**
Active Layer: **Parks and Open Spaces**

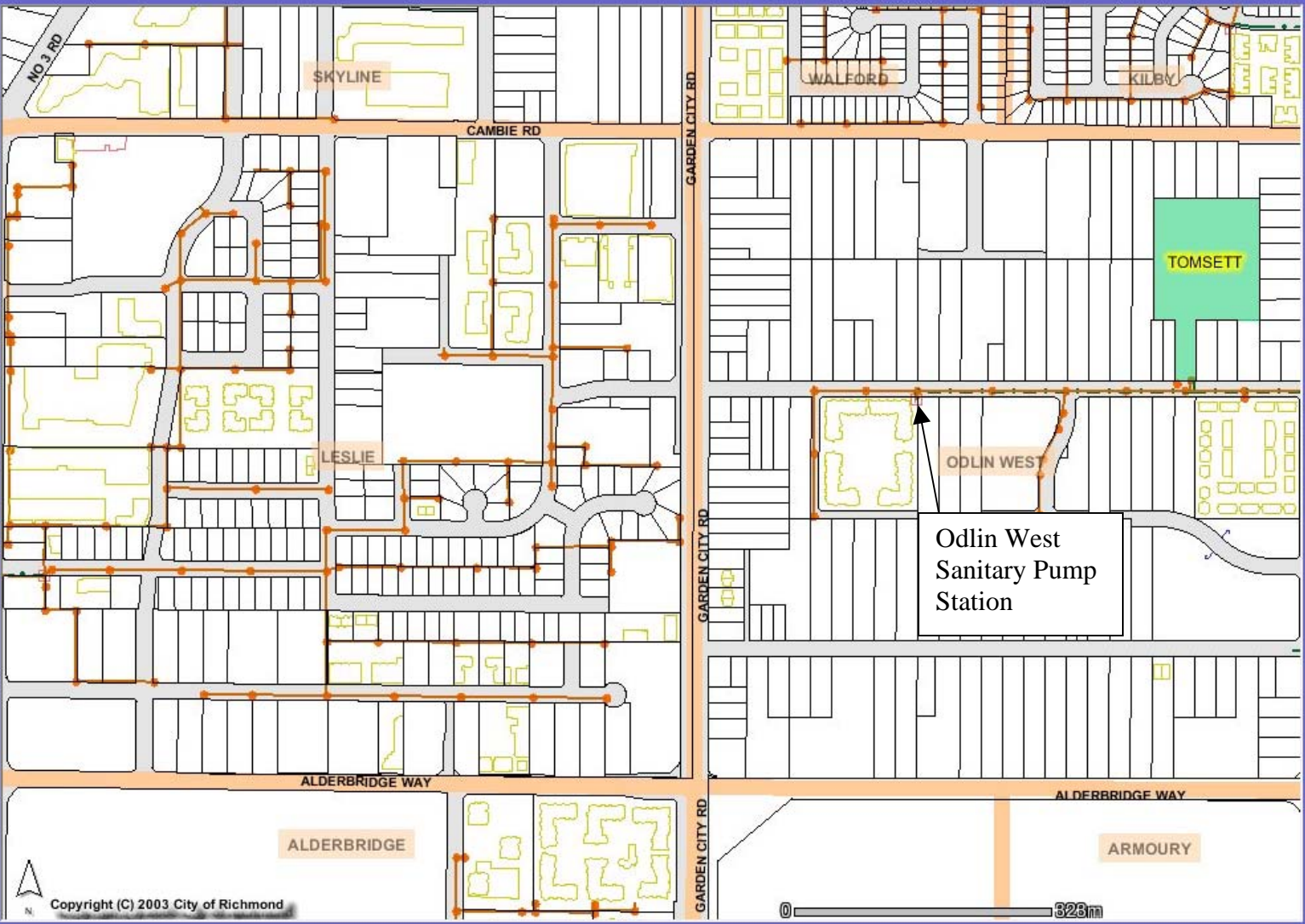

[Services](#) [Layers](#) [Legend](#)
 Search by:

Legend

PROPERTY

- Air Parcel
- Parcel
- Strata
- Property Links
- City Hall
- Parks and Open Spaces
- Sanitary Main Lines
- Abandon Sanitary Main Lines
- Sanitary Main Lines
- Sanitary Forcemain Lines
- Sanitary Trunk Lines
- Sanitary Manholes
- Sanitary Pumpstation
- Sanitary Catchments

REFRESH MAP

T.3921 Addendum 2 Figure 1

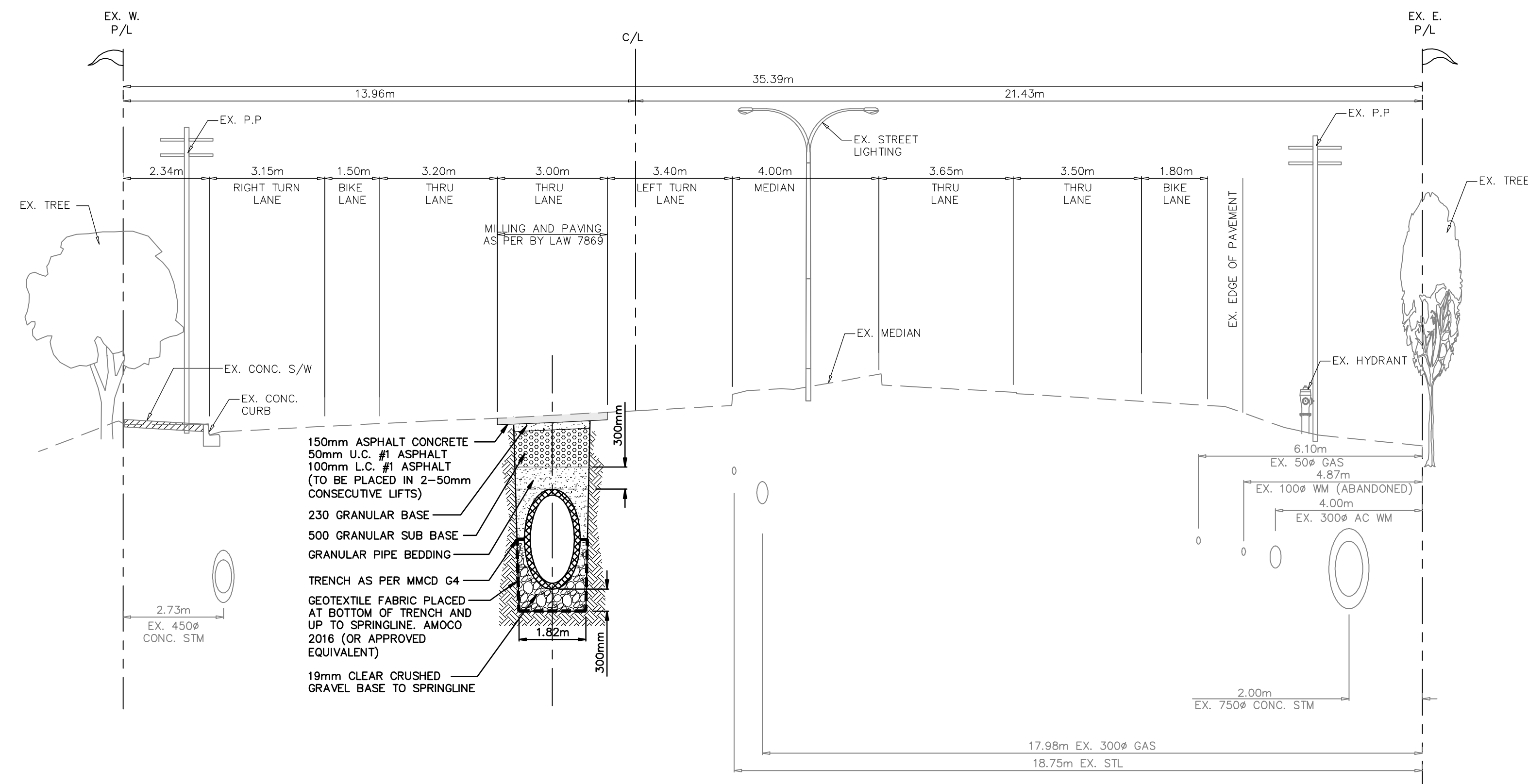

GARDEN CITY ROAD- TYPICAL CROSS SECTION
(STA: 5+088.40 - 5+909.32)
 SCALE H 1:100
 V 1:50

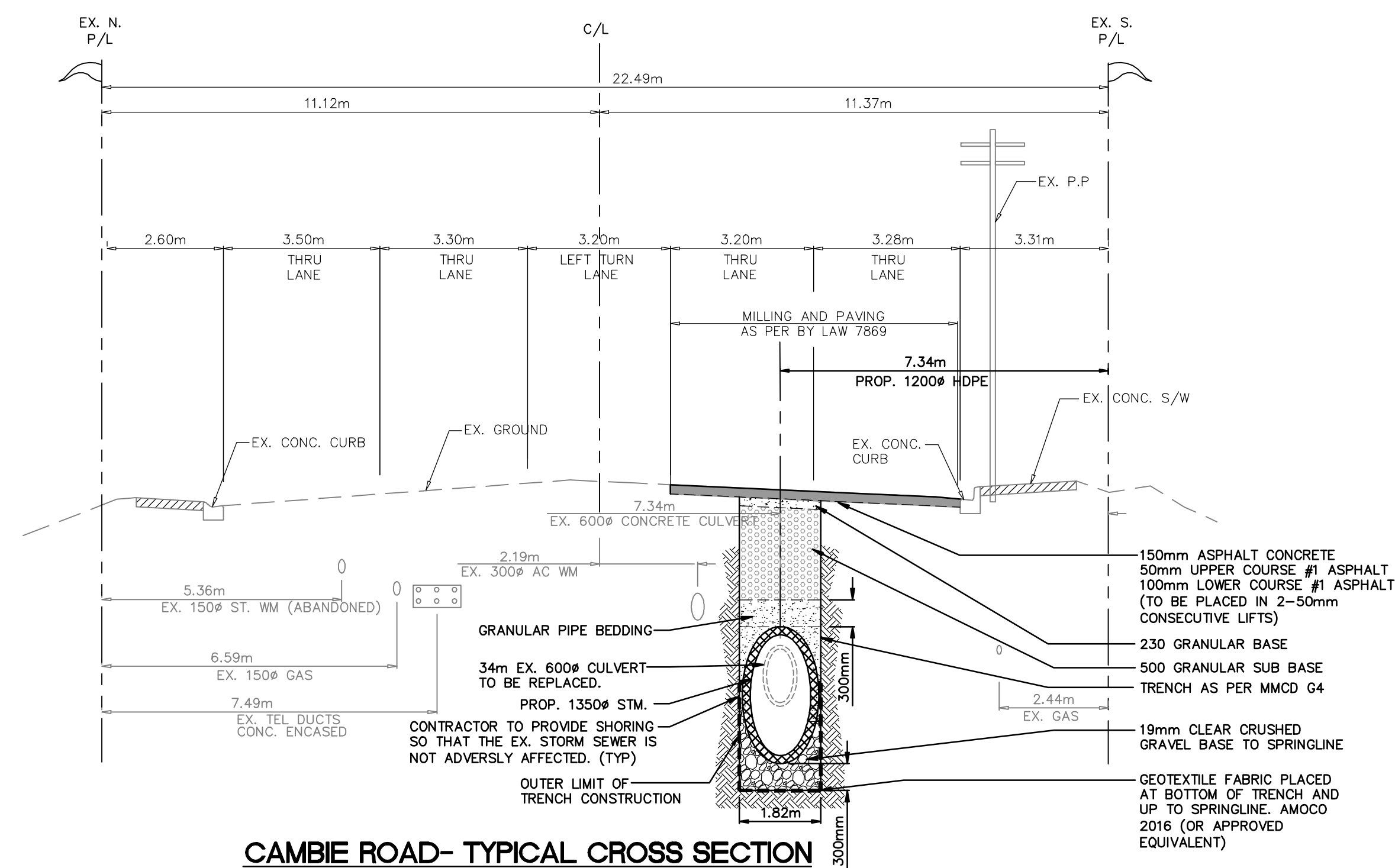

CAMBIE ROAD- TYPICAL CROSS SECTION
(STA: 1+628.36 - 1+661.93)
 SCALE H 1:100
 V 1:50

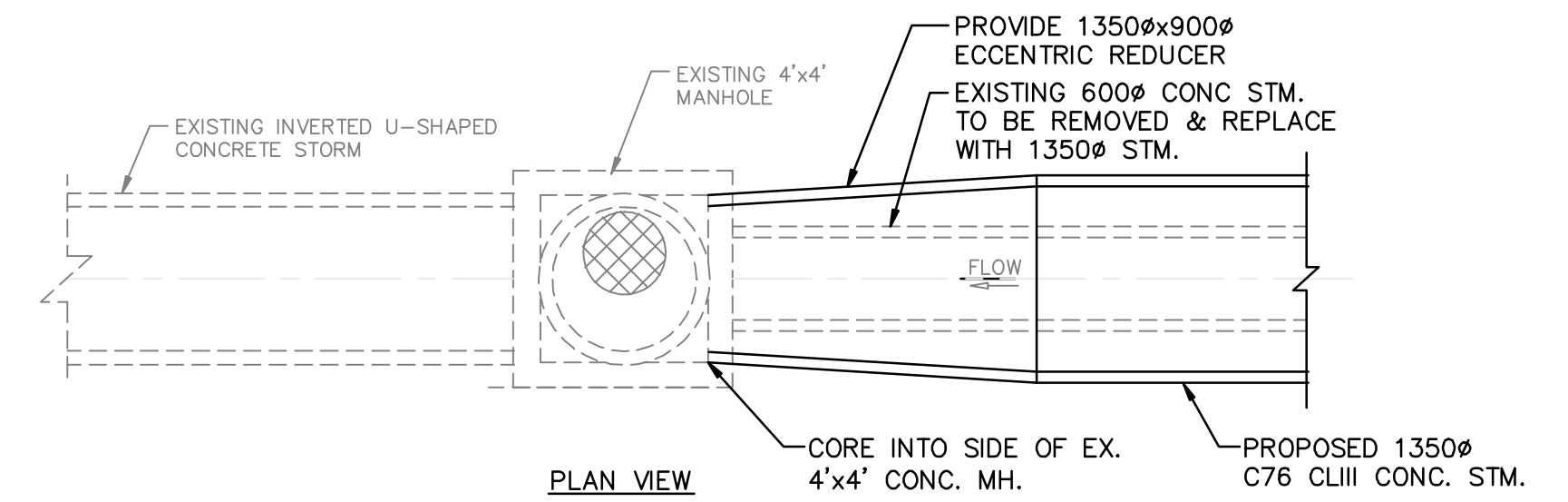

DETAIL 2 - CONNECTION TO EX. CONCRETE BOX CULVERT

City of Richmond
 6911 No. 3 Road Richmond B.C. V6Y 2C1

TITLE: STORM SEWER CONSTRUCTION
GARDEN CITY ROAD
FROM ALDERBRIDGE WAY TO CAMBIE ROAD
AND
CAMBIE ROAD
FROM SEYMOUR ROAD TO GARDEN CITY ROAD

DESIGN: JSB
 DRAWN: JSB/NF
 CHECKED: MEC
 ENGINEER: MEC

DWG. No: **LC-1151**
 SCALE:
 SEC. No: _____

DATE: JULY 2009
 SHI. No: **5 OF 5**

APLIN MARTIN
 CONSULTANTS LTD
 201-12448 82 Avenue, Surrey, B.C. Canada V3W 3E9
 Tel: (604) 597-9058, Fax: (604) 597-9061, E-mail: general@aplinmartin.com

BENCHMARK
 ALL ELEVATIONS ARE TO GEODETIC DATUM AND REFER TO RICHMOND BENCHMARK NUMBER:

 ELEVATION _____ FIELD BOOK No _____
 CITY WORK ORDER No _____ TENDER / PROJECT No _____
 CONTRACTOR WORK ORDER No _____ ACCOUNT No _____

REFERENCE DRAWINGS

PROPERTY ACQUISITION	Aq	_____
SURVEY PLAN & PROFILE	Pp	_____
ROAD CONSTRUCTION	Oc	_____
STORM SEWER INSTALLATION	Lc	_____
WATERMAIN INSTALLATION	Wc	_____
ORNAMENTAL STREET LIGHTING	Tc	_____
TRAFFIC SIGNALS	Ec	_____
SANITARY SEWER INSTALLATION	Sc	_____
OTHER		_____

NOTE - PROVE LOCATION OF ALL UTILITIES / SERVICES BEFORE STARTING CONSTRUCTION.

No	DATE	BY	CHK.	DESCRIPTION
10	AUG. 23, 2010	RHS	MEC	REVISED GEOTEXTILE AND BEDDING NOTES
9	JUL. 12, 2010	KF	MEC	REVISED ALIGNMENT ON CAMBIE ROAD
8	MAY 17, 2010	KF	MEC	REVISED TYPICAL SECTIONS & DETAILS
7	APR. 06, 2010	KF	MEC	REVISED TYPICAL SECTION
6	OCT. 05, 2009	JSB	MEC	REVISED EXISTING GAS LOCATION
5	AUG. 20, 2009	RHS	MEC	ISSUED FOR TENDER
4	JUL. 20, 2009	JSB	MEC	DETAILED DESIGN SUBMISSION 95%
3	MAR. 18, 2009	JSB	MEC	REVISED PRELIMINARY DESIGN
2	DEC. 17, 2008	RCW	MEC	REVISED PRELIMINARY DESIGN
No	DATE	BY	CHK.	DESCRIPTION

B.C. GAS SERVICE RECORDS, BURNHAMPT TELEPHONE, 30-30-ROD
 THE DEVELOPER OR CONTRACTOR SHALL BE RESPONSIBLE FOR DETERMINING GAS SERVICE LINES, AND WHERE NECESSARY, ARRANGE FOR
 THEIR RELOCATION IN ORDER TO FACILITATE INSTALLATION OF THE WORKS SHOWN ON THESE PLANS. A LIST OF SERVICE LINE LOCATIONS MAY BE OBTAINED FROM
 B.C. GAS SERVICES



City of Richmond

August 23, 2010
File: 10-6340-20-P.08302/Vol 01

Engineering
Telephone: 604-276-4289
Fax: 604-276-4197

TO THOSE WHO HAVE RECEIVED COPIES OF T.3921

Dear Sir/Madam:

**Re: Contract T.3921
Addendum No. 3
Storm Sewer Construction Garden City Road: Alderbridge Way to Cambie Road**

This addendum forms part of the Contract Documents and shall be read, interpreted and coordinated with all other parts. The costs of all work contained herein shall be included in the Contract Price. The following revisions supersede the information contained in the original Contract Document to the extent referenced and shall become part thereof.

Tenderers shall acknowledge receipt of this addendum by inserting its number and date where provided for on the Form of Tender.

1) Section C – Item 1.2 Agreement – The Work – Start / Completion Dates

a) Delete "...November 30, 2010." and replace with "...March 31, 2011."

2) SSP3 – Contract Time

a) Delete "...November 30, 2010." and replace with "...March 31, 2011. Substantial Performance of the Work is to be achieved no later than 40 working days from the commencement date subject to the provisions of the Contract Documents for adjustments to the Contract Time."

3) ITT – Tender Closing Date

a) Tender closing date is amended to 3:00pm local time, Tuesday, August 31, 2010.

Sincerely,

FOR:

Milton Chan
Engineering & Public Works